

This Drawing and its Contents are the
 Proprietary Property of M&A CLEARING
 M&A/R/A, INC. and shall not be used for
 the purpose it is provided for.

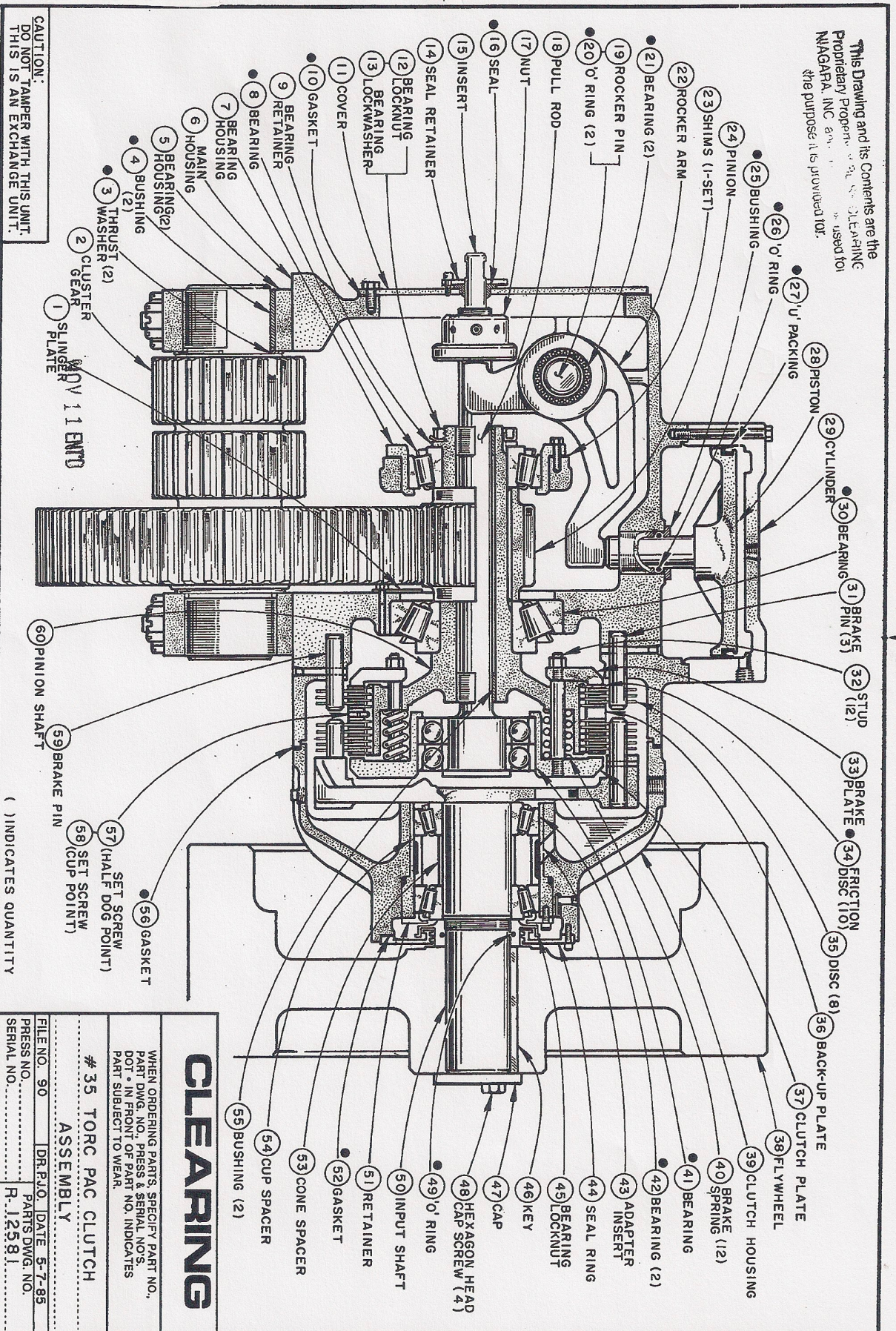

CAUTION:
 DO NOT TAMPER WITH THIS UNIT.
 THIS IS AN EXCHANGE UNIT.

CLEARING

WHEN ORDERING PARTS, SPECIFY PART NO.,
 PART DWG. NO., PRESS & SERIAL NOS.
 DOT • IN FRONT OF PART NO. INDICATES
 PART SUBJECT TO WEAR.

# 35 TORC PAC CLUTCH ASSEMBLY	
FILE NO. 90	DR. P.L.O. DATE 5-7-89
PRESS NO.	PARTS DWG. NO.
SERIAL NO.	R. 12581

No.	Description	No.	Description
1	Slinger Plate	31	Brake Pin (3)
2	Cluster Gear	32	Stud (2)
3•	Thrust Washer (2)	33	Brake Plate
4•	Bushing (2)	34•	Friction Disc (10)
5	Bearing Housing (2)	35	Disc (8)
6	Main Housing	36	Back-Up Plate
7	Bearing Housing	37	Clutch Plate
8•	Bearing	38	Flywheel
9	Bearing Retainer	39	Clutch Housing
10•	Gasket	40	Brake Spring (12)
11	Cover	41•	Bearing
12	Bearing Locknut	42•	Bearing (2)
13	Bearing Lockwasher	43	Adapter Insert
14	Seal Retainer	44	Seal Ring
15	Insert	45	Bearing Locknut
16•	Seal	46	Key
17	Nut	47	Cap
18	Pull Rod	48	Hexagon Head Cap Screw (4)
19	Rocker Pin	49•	"O" Ring
20•	"O" Ring (2)	50	Input Shaft
21•	Bearing (2)	51	Retainer
22	Rocker Arm	52•	Gasket
23	Shims (I-Set)	53	Cone Spacer
24	Pinion	54	Cup Spacer
25•	Bushing	55	Bushing (2)
26•	"O" Ring	56•	Gasket
27•	"U" Packing	57	Set Screw (Half Dog Point)
28	Piston	58	Set Screw (Cup Point)
29	Cylinder	59	Brake Pin (3)
30•	Bearing	60	Pinion Shaft

WHEN ORDERING PARTS, SPECIFY PART NO., PART DWG NO., PRESS & SERIAL NO'S. DOT • IN FRONT OF P/
() INDICATES QUANTITY

CAUTION: DO NOT TAMPER WITH THIS UNIT. THIS IS AN EXCHANGE UNIT.